

NOTES :

1. THE STRUCTURAL ROAD ELEMENTS SHOWN ARE THE MINIMUM REQUIREMENTS. SOILS TEST RESULTS SHALL BE USED TO DESIGN THE ROAD STRUCTURE.
2. ALL UTILITY SERVICES AND SERVICE CONNECTIONS SHALL BE INSTALLED PRIOR TO FINAL PAVING.
3. ANY PERMANENT WORKS ON PRIVATE PROPERTY SHALL BE PROTECTED BY A REGISTERED EASEMENT OR RIGHT OF WAY.
4. WHERE THE DEPTH OF ANY UTILITY PROPOSED TO BE LOCATED WITHIN THE LANE IS GREATER THAN 1.0 m FROM THE LANE SURFACE, AND WHERE MORE THAN ONE UTILITY IS PROPOSED FOR INSTALLATION, PRE-APPROVAL FROM THE CITY ENGINEER IS REQUIRED.

6 m LANE



REVISED:	APPROVED:
APPROVED:	DWG. NO.
DATE: MAR. 2002	DR-1
DRAWN: THJ	

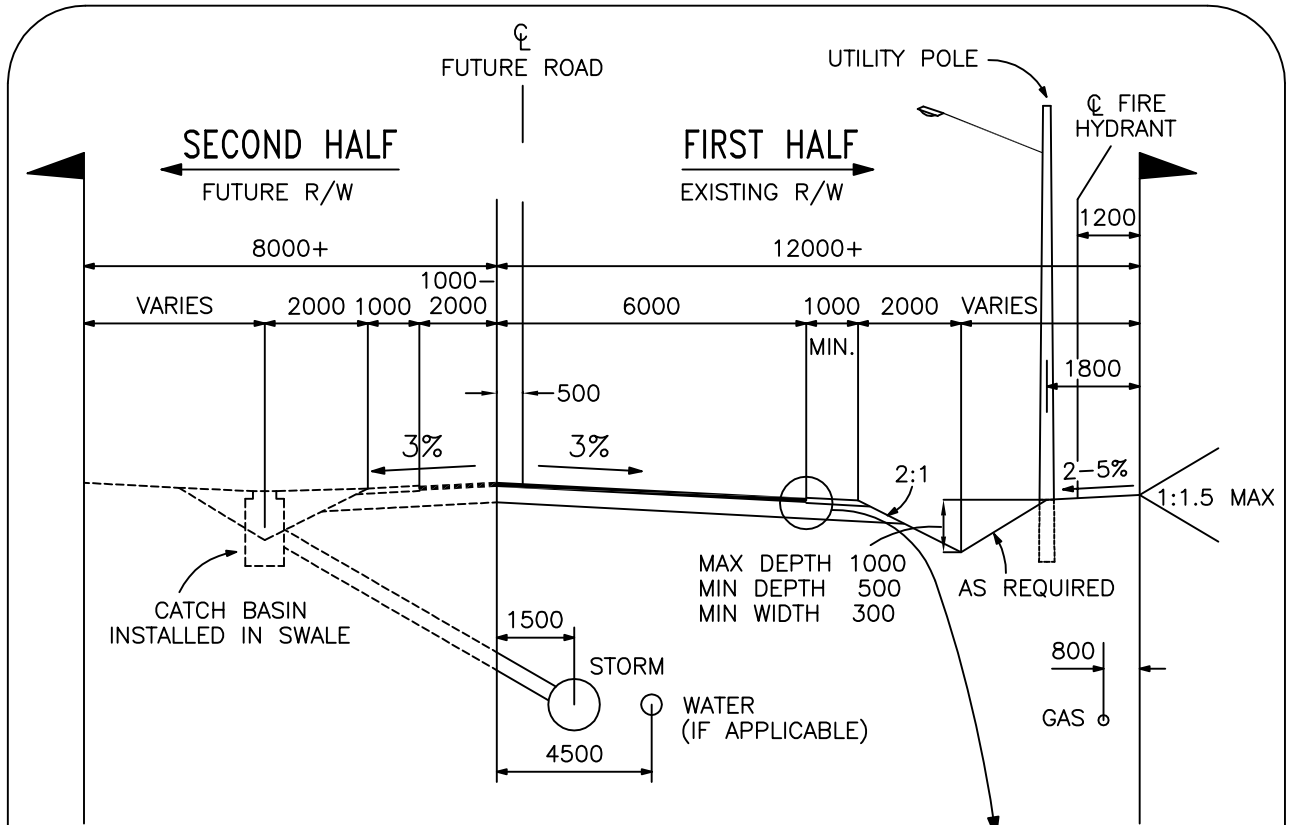

- MIN. 35mm ASPHALT SURFACE COURSE
- MIN. 40mm ASPHALT BASE COURSE
- MIN. 75mm OF 20mm CRUSH SHOULDER TO 95% MODIFIED PROCTOR
- MIN. 100mm OF 20mm CRUSH BASE TO 95% MODIFIED PROCTOR
- MIN. 300mm OF 75mm MINUS GRAVEL SUBBASE TO 95% MODIFIED PROCTOR

SUBGRADE TO 90% MODIFIED PROCTOR

**NOTES:**

1. THE STRUCTURAL ROAD ELEMENTS SHOWN ARE THE MINIMUM REQUIREMENTS. SOILS TEST RESULTS SHALL BE USED TO DESIGN THE ROAD STRUCTURE.
2. ALL UTILITY SERVICES AND SERVICE CONNECTIONS SHALL BE INSTALLED PRIOR TO FINAL PAVING.
3. ANY PERMANENT WORKS ON PRIVATE PROPERTY SHALL BE PROTECTED BY A REGISTERED EASEMENT OR RIGHT OF WAY AS DETERMINED BY THE CITY.
4. DITCHES SHALL BE PIPED PAST UTILITY POLES AND FIRE HYDRANTS WHERE REQUIRED.
5. PROVISION MUST BE MADE FOR OFFSITE DRAINAGE AT THE FUTURE ROAD CENTRELINE.
6. SECOND HALF PAVEMENT WIDTH SHALL BE SPECIFIED BY THE CITY ENGINEER.
7. PIPED STORM SEWERS ARE REQUIRED WHERE CONTROL OF STORM WATER RUN OFF TO PRE-DEVELOPMENT FLOWS IS A REQUIREMENT.
8. HIGH BACKED CONCRETE CURBS ARE REQUIRED ON THE DOWNHILL SIDE OF A RURAL ROAD WHERE IT IS NECESSARY TO PREVENT WATER FROM ROAD DRAINING ONTO DOWNHILL LOTS.

**RURAL HALF ROAD - 12.0m R/W**



**CITY OF CHILLIWACK**

REVISED:

APPROVED:

APPROVED:

DWG. NO.

DATE:

05/94

**DR-2**

DRAWN:

SEH

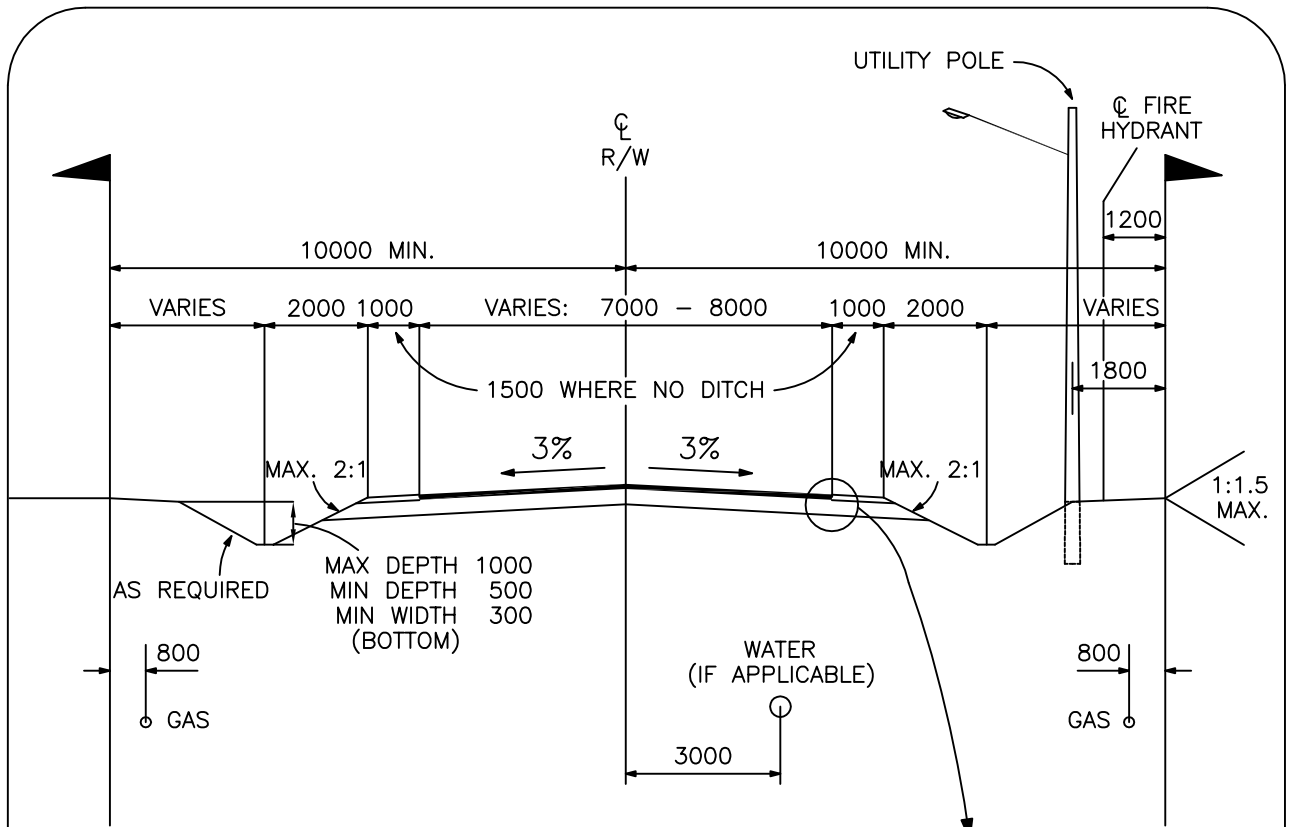

MIN. 35mm ASPHALT SURFACE COURSE  
 MIN. 40mm ASPHALT BASE COURSE  
 MIN. 75mm OF 20mm CRUSH SHOULDER  
 TO 95% MODIFIED PROCTOR  
 MIN. 100mm OF 20mm CRUSH BASE  
 TO 95% MODIFIED PROCTOR  
 MIN. 300mm OF 75mm MINUS GRAVEL SUBBASE  
 TO 95% MODIFIED PROCTOR

SUBGRADE TO 90% MODIFIED PROCTOR

NOTES:

1. THE STRUCTURAL ROAD ELEMENTS SHOWN ARE THE MINIMUM REQUIREMENTS. SOILS TEST RESULTS SHALL BE USED TO DESIGN THE ROAD STRUCTURE.
2. ALL UTILITY SERVICES AND SERVICE CONNECTIONS SHALL BE INSTALLED PRIOR TO FINAL PAVING.
3. ANY PERMANENT WORKS ON PRIVATE PROPERTY SHALL BE PROTECTED BY A REGISTERED EASEMENT OR RIGHT OF WAY AS DETERMINED BY THE CITY.
4. DITCHES SHALL BE PIPED PAST UTILITY POLES AND FIRE HYDRANTS WHERE REQUIRED.
5. PAVEMENT WIDTH SHALL BE SPECIFIED BY THE MUNICIPAL ENGINEER.
6. PIPED STORM SEWERS ARE REQUIRED WHERE CONTROL OF STORM WATER RUN OFF TO PRE-DEVELOPMENT FLOWS IS A REQUIREMENT.
7. HIGH BACKED CONCRETE CURBS ARE REQUIRED ON THE DOWNHILL SIDE OF A RURAL ROAD WHERE IT IS NECESSARY TO PREVENT WATER FROM ROAD DRAINING ONTO DOWNHILL LOTS.

RURAL ROAD - 20.0m R/W



REVISED:

APPROVED:

APPROVED:

DWG. NO.

DATE:

05/94

DR-3

DRAWN:

SEH

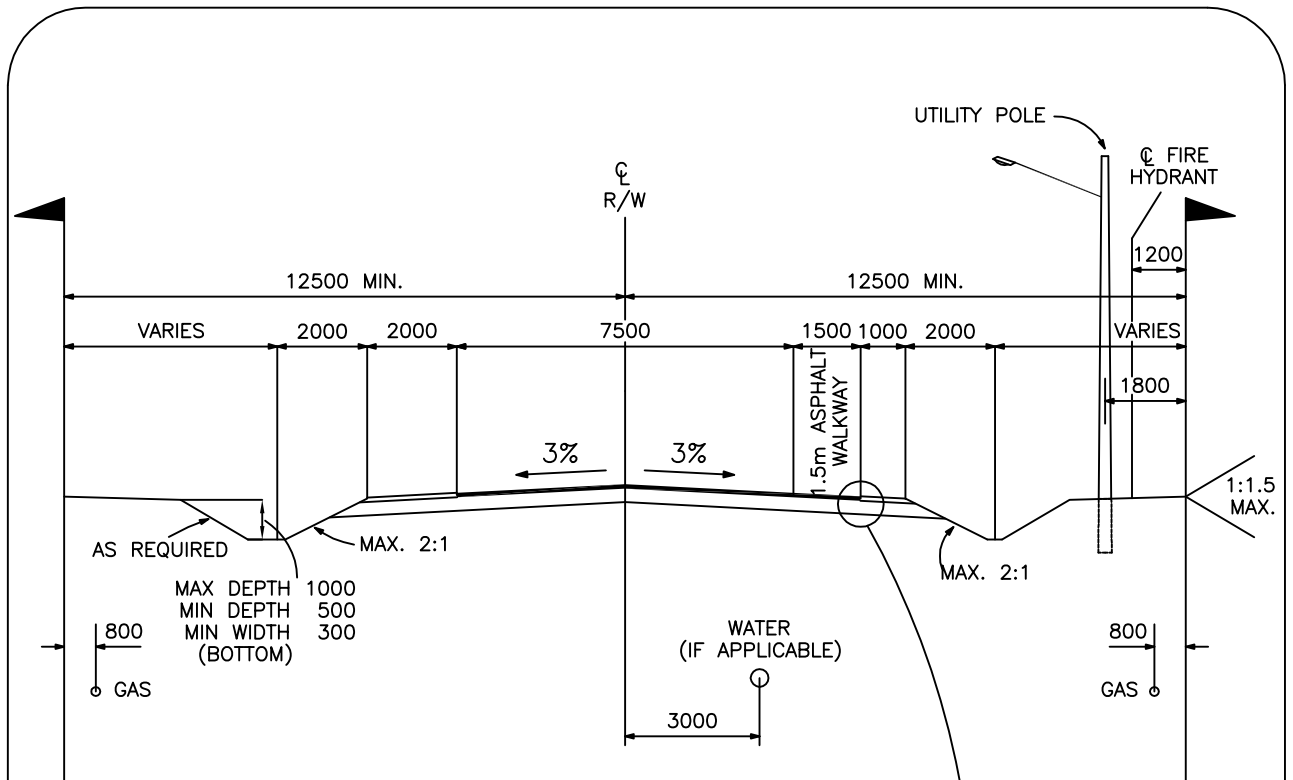

AS REQUIRED  
 MAX DEPTH 1000  
 MIN DEPTH 500  
 MIN WIDTH (BOTTOM) 300

MIN. 35mm ASPHALT SURFACE COURSE  
 MIN. 40mm ASPHALT BASE COURSE  
 MIN. 75mm OF 20mm CRUSH SHOULDER TO 95% MODIFIED PROCTOR  
 MIN. 100mm OF 20mm CRUSH BASE TO 95% MODIFIED PROCTOR  
 MIN. 300mm OF 75mm MINUS GRAVEL SUBBASE TO 95% MODIFIED PROCTOR

SUBGRADE TO 90% MODIFIED PROCTOR

**NOTES:**

1. THE STRUCTURAL ROAD ELEMENTS SHOWN ARE THE MINIMUM REQUIREMENTS. SOILS TEST RESULTS SHALL BE USED TO DESIGN THE ROAD STRUCTURE.
2. ALL UTILITY SERVICES AND SERVICE CONNECTIONS SHALL BE INSTALLED PRIOR TO FINAL PAVING.
3. ANY PERMANENT WORKS ON PRIVATE PROPERTY SHALL BE PROTECTED BY A REGISTERED EASEMENT OR RIGHT OF WAY AS DETERMINED BY THE CITY.
4. DITCHES SHALL BE PIPED PAST UTILITY POLES AND FIRE HYDRANTS WHERE REQUIRED.
5. PROVISION SHALL BE MADE FOR A 1.5m WIDE ASPHALT WALKWAY ON ONE SIDE. THE WALKWAY IS TO BE DELINEATED BY A SOLID PAINTED WHITE LINE.
6. PIPED STORM SEWERS ARE REQUIRED WHERE CONTROL OF STORM WATER RUN OFF TO PRE-DEVELOPMENT FLOWS IS A REQUIREMENT.
7. HIGH BACKED CONCRETE CURBS ARE REQUIRED ON THE DOWNHILL SIDE OF A RURAL ROAD WHERE IT IS NECESSARY TO PREVENT WATER FROM ROAD DRAINING ONTO DOWNHILL LOTS.

RURAL ARTERIAL & RURAL COLLECTOR - 25.0m R/W

REVISED:

APPROVED:



APPROVED:

DWG. NO.

DATE: 05/94

DR-4

DRAWN: SEH

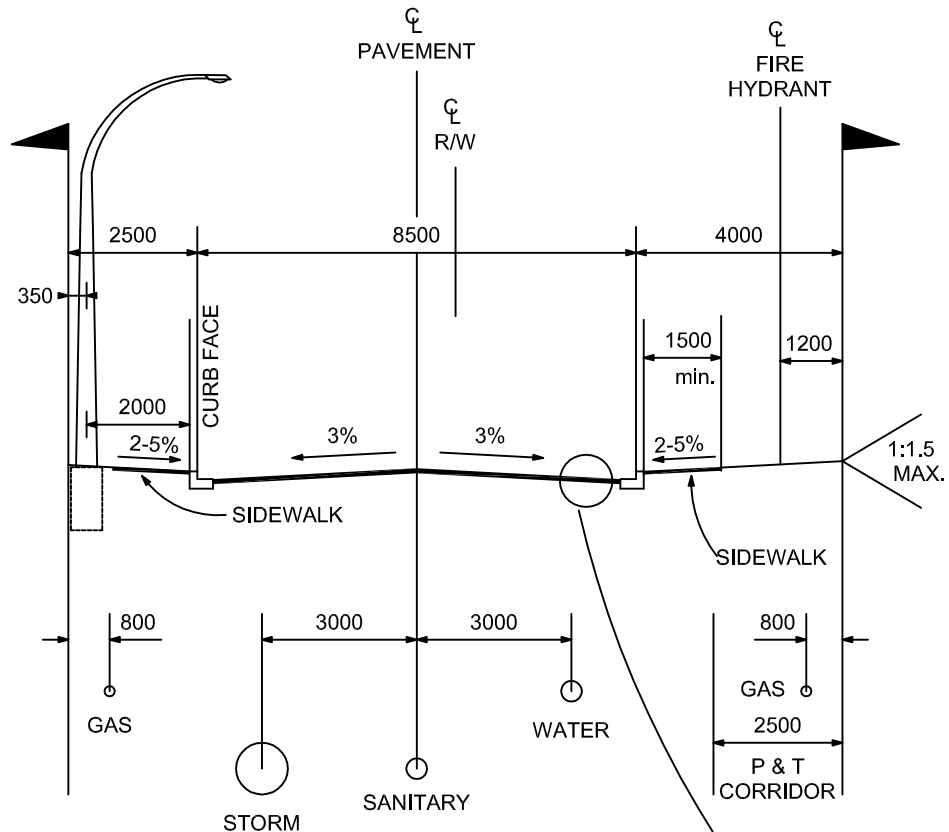

MIN. 35mm ASPHALT SURFACE COURSE  
 MIN. 40mm ASPHALT BASE COURSE  
 MIN. 100mm OF 20mm CRUSH BASE  
 TO 95% MODIFIED PROCTOR

MIN. 300mm OF 75mm MINUS GRAVEL SUBBASE  
 TO 95% MODIFIED PROCTOR

SUBGRADE TO 90% MODIFIED PROCTOR

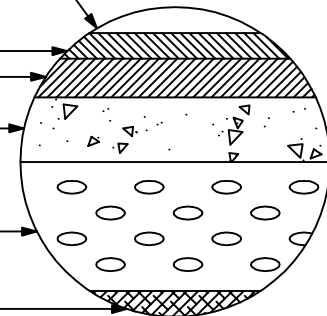

**NOTES:**

1. THE STRUCTURAL ROAD ELEMENTS SHOWN ARE THE MINIMUM REQUIREMENTS. SOILS TEST RESULTS SHALL BE USED TO DESIGN THE ROAD STRUCTURE.
2. ALL UTILITY SERVICES AND SERVICE CONNECTIONS SHALL BE INSTALLED PRIOR TO FINAL PAVING.
3. ANY PERMANENT WORKS ON PRIVATE PROPERTY SHALL BE PROTECTED BY A REGISTERED EASEMENT OR RIGHT OF WAY AS DETERMINED BY THE CITY.
4. 2.5m P & T CORRIDOR SHOWN IS NOT COMPATIBLE TO 3 PHASE WIRING. CONSULT WITH B.C. HYDRO AS TO SERVICING REQUIREMENTS.
5. APPLICABLE FOR CUL DE SAC ROADS ONLY.

URBAN - 8.5m PAVEMENT - 15.0m R/W



REVISED: 01/10

APPROVED:

APPROVED:

DWG. NO.

DATE: 05/94

DR-5

DRAWN: SEH

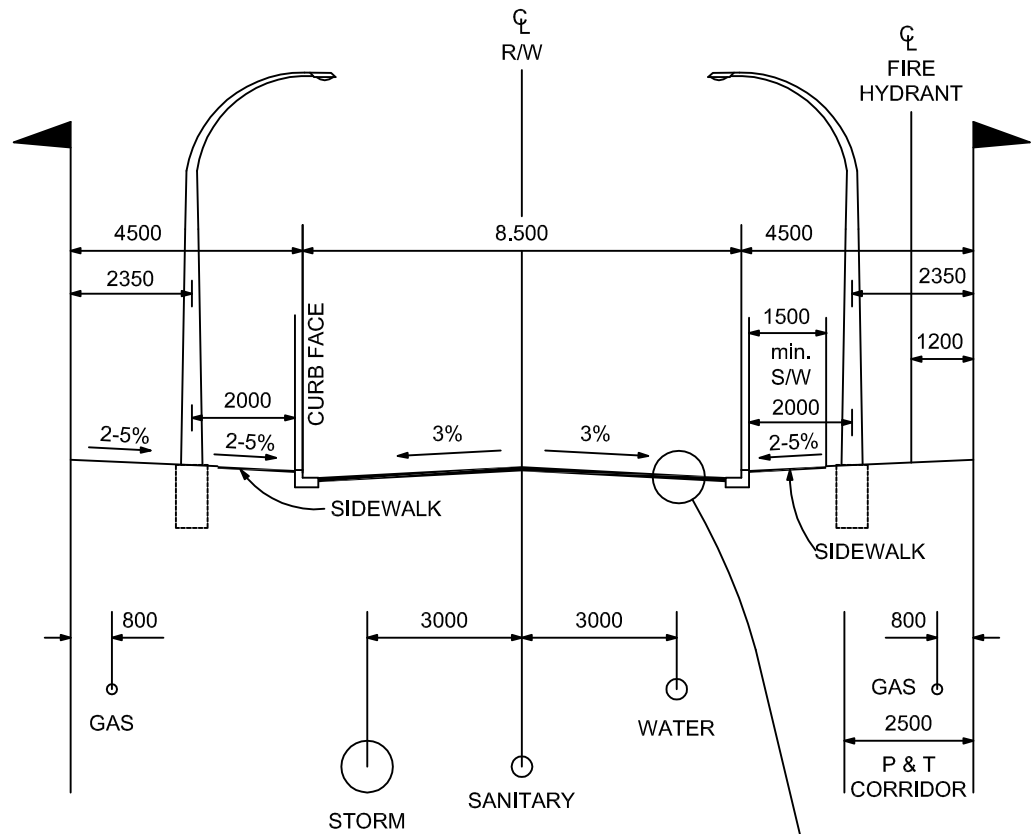

MIN. 35mm ASPHALT SURFACE COURSE  
 MIN. 40mm ASPHALT BASE COURSE  
 MIN. 100mm OF 20mm CRUSH BASE  
 TO 95% MODIFIED PROCTOR

MIN. 300mm OF 75mm MINUS GRAVEL SUBBASE  
 TO 95% MODIFIED PROCTOR

SUBGRADE TO 90% MODIFIED PROCTOR

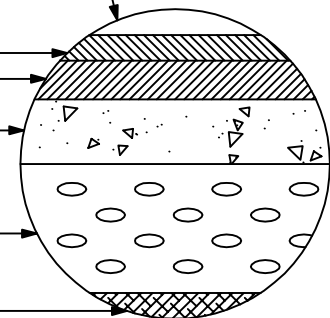

NOTES:

1. THE STRUCTURAL ROAD ELEMENTS SHOWN ARE THE MINIMUM REQUIREMENTS. SOILS TEST RESULTS SHALL BE USED TO DESIGN THE ROAD STRUCTURE.
2. ALL UTILITY SERVICES AND SERVICE CONNECTIONS SHALL BE INSTALLED PRIOR TO FINAL PAVING.
3. ANY PERMANENT WORKS ON PRIVATE PROPERTY SHALL BE PROTECTED BY A REGISTERED EASEMENT OR RIGHT OF WAY AS DETERMINED BY THE CITY.
4. 2.5m P & T CORRIDOR SHOWN IS NOT COMPATABLE TO 3 PHASE WIRING. CONSULT WITH B.C. HYDRO AS TO SERVICING REQUIREMENTS.

URBAN - 8.5 m PAVEMENT - 17.5m R/W



REVISED: 10/01

APPROVED:

APPROVED:

DWG. NO.

DATE: 03/93

DR-6

DRAWN: SEH

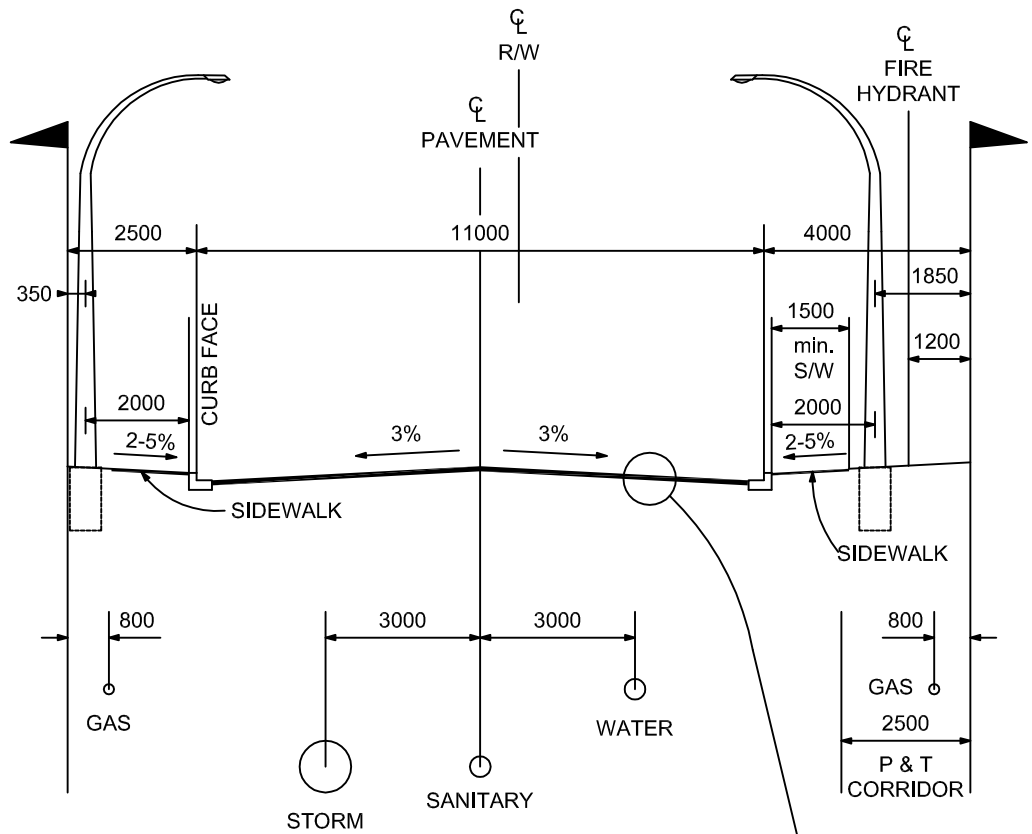

MIN. 35mm ASPHALT SURFACE COURSE  
 MIN. 40mm ASPHALT BASE COURSE  
 MIN. 100mm OF 20mm CRUSH BASE  
 TO 95% MODIFIED PROCTOR

MIN. 300mm OF 75mm MINUS GRAVEL SUBBASE  
 TO 95% MODIFIED PROCTOR

SUBGRADE TO 90% MODIFIED PROCTOR

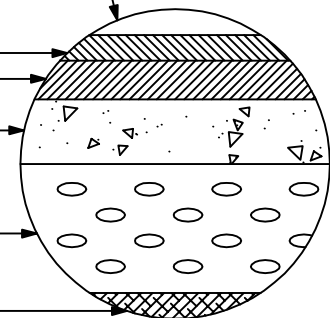

NOTES:

1. THE STRUCTURAL ROAD ELEMENTS SHOWN ARE THE MINIMUM REQUIREMENTS. SOILS TEST RESULTS SHALL BE USED TO DESIGN THE ROAD STRUCTURE.
2. ALL UTILITY SERVICES AND SERVICE CONNECTIONS SHALL BE INSTALLED PRIOR TO FINAL PAVING.
3. ANY PERMANENT WORKS ON PRIVATE PROPERTY SHALL BE PROTECTED BY A REGISTERED EASEMENT OR RIGHT OF WAY AS DETERMINED BY THE CITY.
4. 2.5m P & T CORRIDOR SHOWN IS NOT COMPATIBLE TO 3 PHASE WIRING. CONSULT WITH B.C. HYDRO AS TO SERVICING REQUIREMENTS.

URBAN - 11.0m PAVEMENT - 17.5m R/W



REVISED: 10/01

APPROVED:

APPROVED:

DWG. NO.

DATE: 03/93

DR-7

DRAWN: SEH

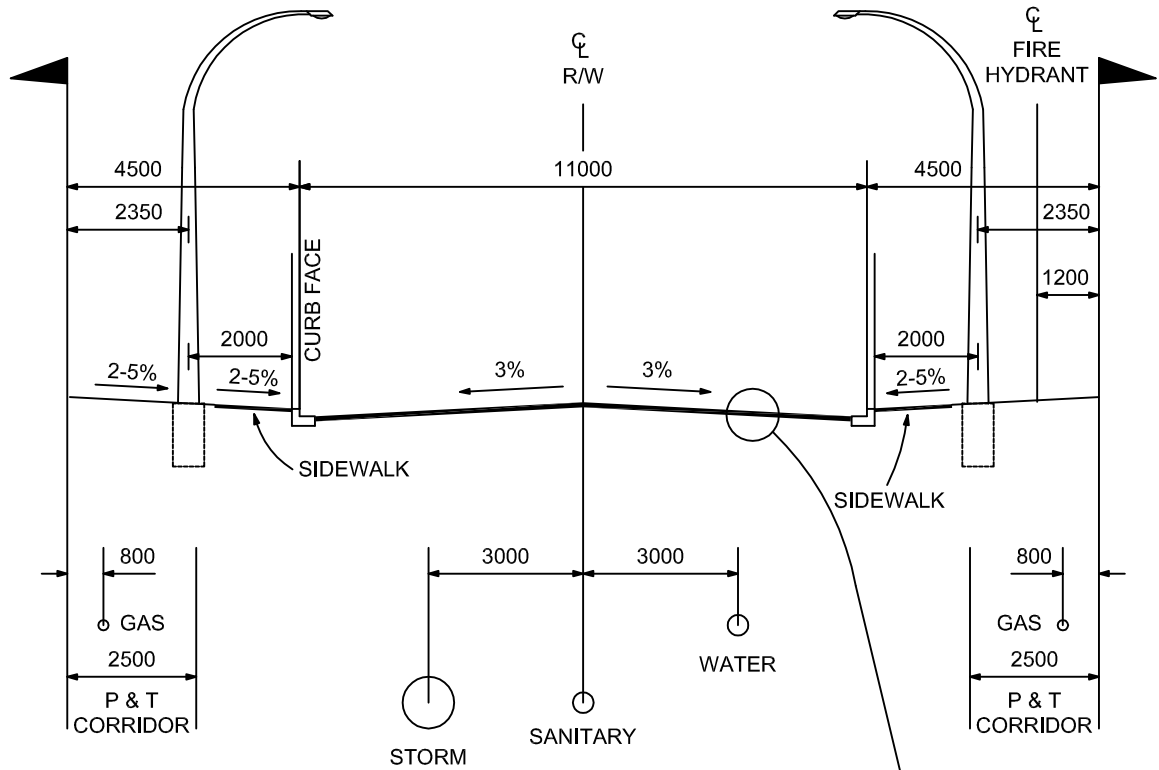

MIN. 35mm ASPHALT SURFACE COURSE  
 MIN. 40mm ASPHALT BASE COURSE  
 MIN. 100mm OF 20mm CRUSH BASE  
 TO 95% MODIFIED PROCTOR

MIN. 300mm OF 75mm MINUS GRAVEL SUBBASE  
 TO 95% MODIFIED PROCTOR

SUBGRADE TO 90% MODIFIED PROCTOR

NOTES:

1. THE STRUCTURAL ROAD ELEMENTS SHOWN ARE THE MINIMUM REQUIREMENTS. SOILS TEST RESULTS SHALL BE USED TO DESIGN THE ROAD STRUCTURE.
2. ALL UTILITY SERVICES AND SERVICE CONNECTIONS SHALL BE INSTALLED PRIOR TO FINAL PAVING.
3. ANY PERMANENT WORKS ON PRIVATE PROPERTY SHALL BE PROTECTED BY A REGISTERED EASEMENT OR RIGHT OF WAY AS DETERMINED BY THE CITY.
4. 2.5m P & T CORRIDOR SHOWN IS NOT COMPATIBLE WITH 3 PHASE WIRING. CONSULT WITH B.C. HYDRO AS TO SERVICING REQUIREMENTS.
5. WHERE 3 PHASE WIRING IS TO BE INSTALLED, STREET LIGHTS ARE TO BE LOCATED AT THE CURB ON BOTH SIDES OF THE ROAD.

URBAN - 11.0m PAVEMENT - 20.0m R/W



REVISED: 10/01

APPROVED:

APPROVED:

DWG. NO.

DATE: 05/94

DR-8

DRAWN: SEH



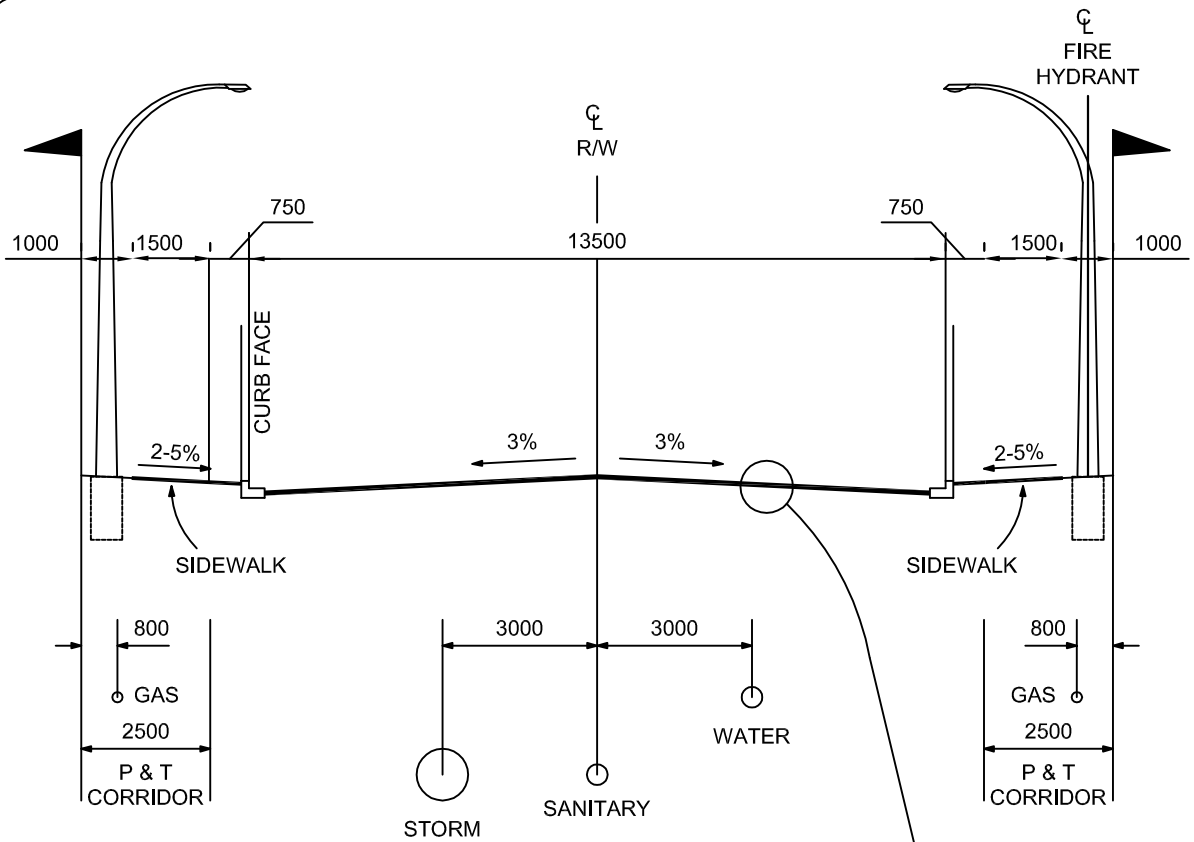

MIN. 35mm ASPHALT SURFACE COURSE  
 MIN. 40mm ASPHALT BASE COURSE  
 MIN. 100mm OF 20mm CRUSH BASE  
 TO 95% MODIFIED PROCTOR

MIN. 300mm OF 75mm MINUS GRAVEL SUBBASE  
 TO 95% MODIFIED PROCTOR

SUBGRADE TO 90% MODIFIED PROCTOR

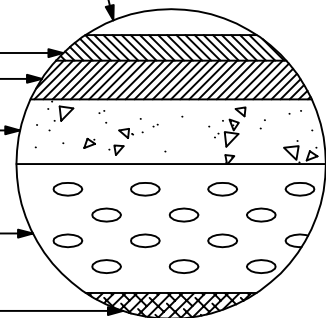

**NOTES:**

1. THE STRUCTURAL ROAD ELEMENTS SHOWN ARE THE MINIMUM REQUIREMENTS. SOILS TEST RESULTS SHALL BE USED TO DESIGN THE ROAD STRUCTURE.
2. ALL UTILITY SERVICES AND SERVICE CONNECTIONS SHALL BE INSTALLED PRIOR TO FINAL PAVING.
3. ANY PERMANENT WORKS ON PRIVATE PROPERTY SHALL BE PROTECTED BY A REGISTERED EASEMENT OR RIGHT OF WAY AS DETERMINED BY THE CITY.
4. 2.5m P & T CORRIDOR SHOWN IS NOT COMPATIBLE WITH 3 PHASE WIRING. CONSULT WITH B.C. HYDRO AS TO SERVICING REQUIREMENTS.

URBAN - 13.5m PAVEMENT - 20.0m R/W



REVISED:

APPROVED:

APPROVED:

DWG. NO.

DATE: 02/10

DR-9

DRAWN: SEH

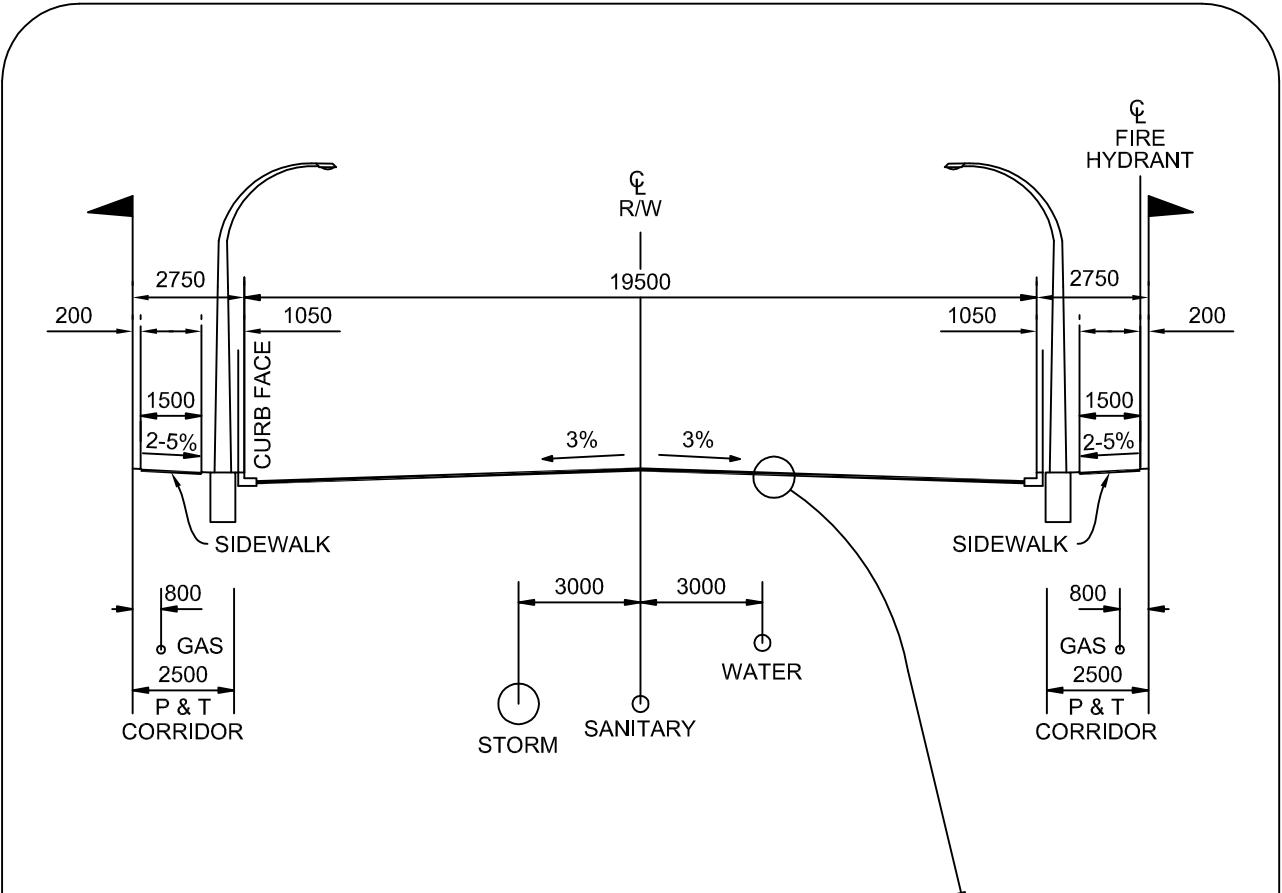

MIN. 35mm ASPHALT SURFACE COURSE  
 MIN. 40mm ASPHALT BASE COURSE  
 MIN. 100mm OF 20mm CRUSH BASE  
 TO 95% MODIFIED PROCTOR

MIN. 300mm OF 75mm MINUS GRAVEL SUBBASE  
 TO 95% MODIFIED PROCTOR

SUBGRADE TO 90% MODIFIED PROCTOR

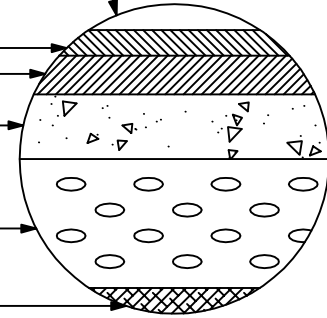

NOTES:

1. THE STRUCTURAL ROAD ELEMENTS SHOWN ARE THE MINIMUM REQUIREMENTS. SOILS TEST RESULTS SHALL BE USED TO DESIGN THE ROAD STRUCTURE.
2. ALL UTILITY SERVICES AND SERVICE CONNECTIONS SHALL BE INSTALLED PRIOR TO FINAL PAVING.
3. ANY PERMANENT WORKS ON PRIVATE PROPERTY SHALL BE PROTECTED BY A REGISTERED EASEMENT OR RIGHT OF WAY AS DETERMINED BY THE CITY.
4. 2.5m P & T CORRIDOR SHOWN IS NOT COMPATABLE WITH 3 PHASE WIRING. CONSULT WITH B.C. HYDRO AS TO SERVICING REQUIREMENTS.

URBAN - 19.5m PAVEMENT - 25.0m R/W



**CITY OF CHILLIWACK**

REVISED:

APPROVED:

APPROVED:

DWG. NO.

DATE: 02/10

DR-10

DRAWN: SEH

"Land Development Bylaw 2014, No. 3055"

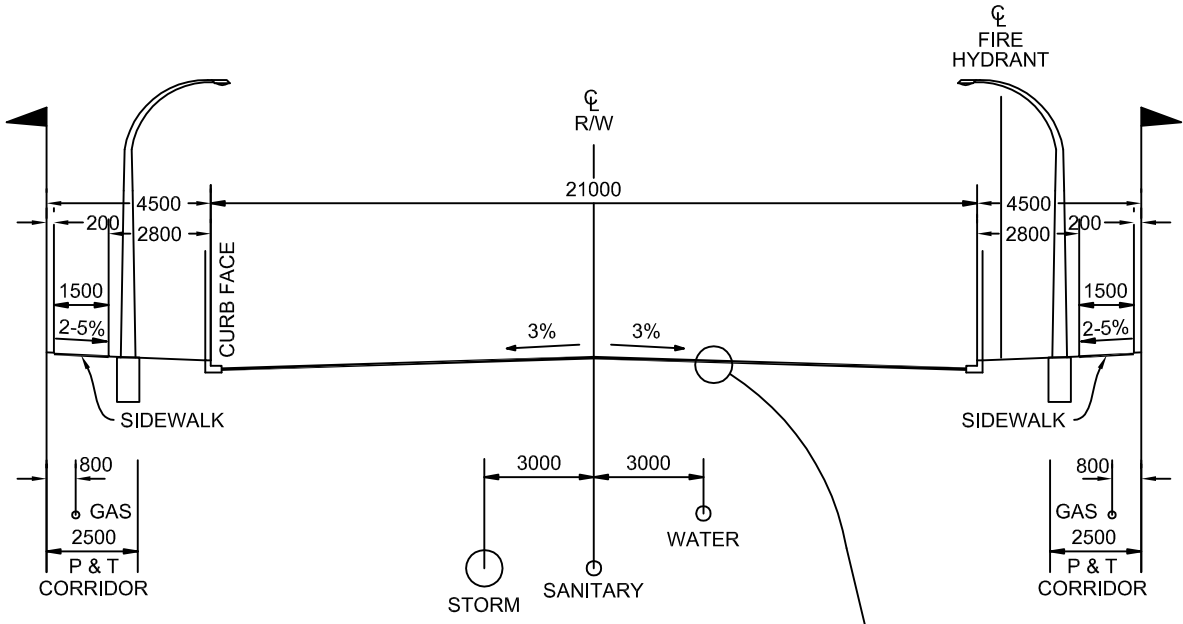

- MIN. 35mm ASPHALT SURFACE COURSE
- MIN. 40mm ASPHALT BASE COURSE
- MIN. 100mm OF 20mm CRUSH BASE TO 95% MODIFIED PROCTOR
- MIN. 300mm OF 75mm MINUS GRAVEL SUBBASE TO 95% MODIFIED PROCTOR
- SUBGRADE TO 90% MODIFIED PROCTOR

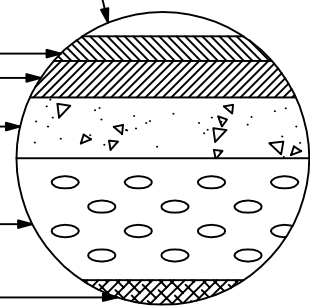

NOTES:

1. THE STRUCTURAL ROAD ELEMENTS SHOWN ARE THE MINIMUM REQUIREMENTS. SOILS TEST RESULTS SHALL BE USED TO DESIGN THE ROAD STRUCTURE.
2. ALL UTILITY SERVICES AND SERVICE CONNECTIONS SHALL BE INSTALLED PRIOR TO FINAL PAVING.
3. ANY PERMANENT WORKS ON PRIVATE PROPERTY SHALL BE PROTECTED BY A REGISTERED EASEMENT OR RIGHT OF WAY AS DETERMINED BY THE CITY.
4. 2.5m P & T CORRIDOR SHOWN IS NOT COMPATIBLE WITH 3 PHASE WIRING. CONSULT WITH B.C. HYDRO AS TO SERVICING REQUIREMENTS.

URBAN - 21.0m PAVEMENT - 30.0m R/W



REVISED:	APPROVED:
APPROVED:	DWG. NO.
DATE: 02/10	DR-11
DRAWN: SEH	

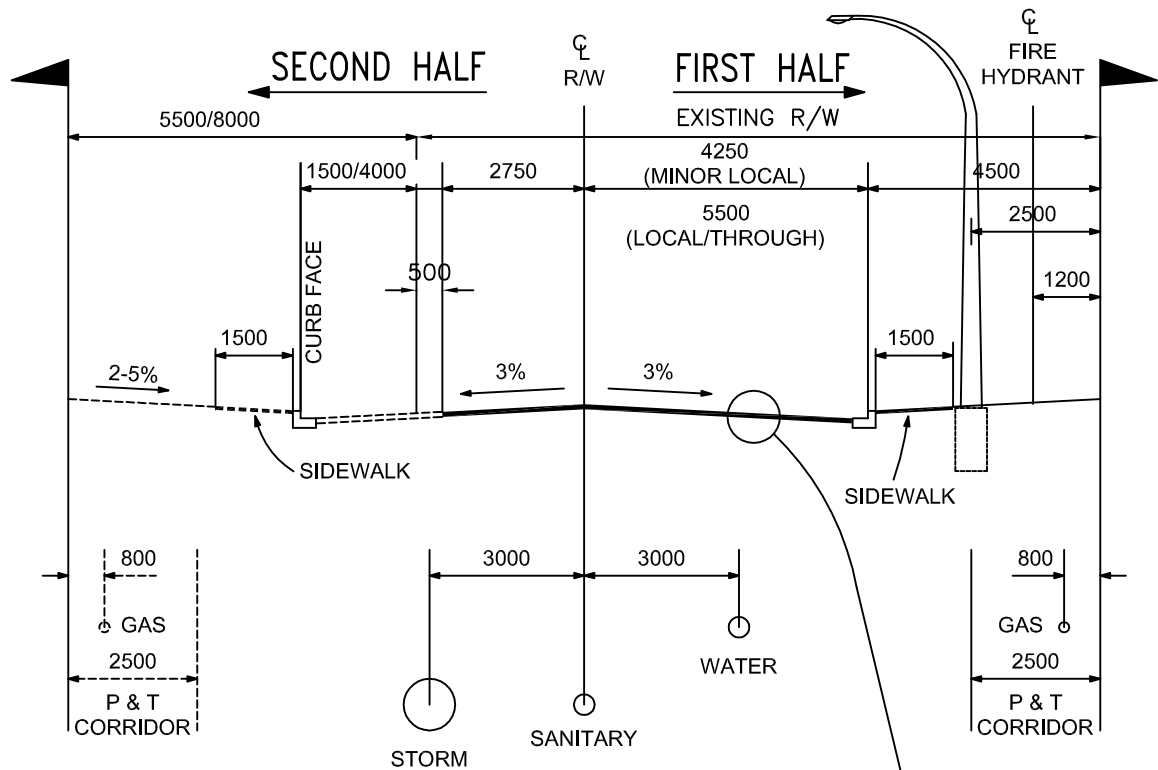

MIN. 35mm ASPHALT SURFACE COURSE  
 MIN. 40mm ASPHALT BASE COURSE  
 MIN. 100mm OF 20mm CRUSH BASE  
 TO 95% MODIFIED PROCTOR

MIN. 300mm OF 75mm MINUS GRAVEL SUBBASE  
 TO 95% MODIFIED PROCTOR

SUBGRADE TO 90% MODIFIED PROCTOR

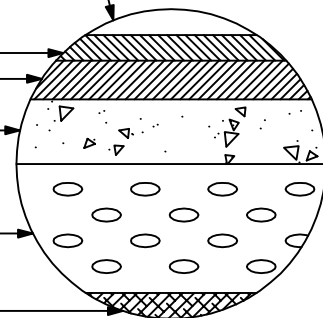

NOTES:

1. THE STRUCTURAL ROAD ELEMENTS SHOWN ARE THE MINIMUM REQUIREMENTS. SOILS TEST RESULTS SHALL BE USED TO DESIGN THE ROAD STRUCTURE.
2. ALL UTILITY SERVICES AND SERVICE CONNECTIONS SHALL BE INSTALLED PRIOR TO FINAL PAVING.
3. ANY PERMANENT WORKS ON PRIVATE PROPERTY SHALL BE PROTECTED BY A REGISTERED EASEMENT OR RIGHT OF WAY AS DETERMINED BY THE CITY.
4. 2.5m P & T CORRIDOR SHOWN IS NOT COMPATABLE WITH 3 PHASE WIRING. CONSULT WITH B.C. HYDRO AS TO SERVICING REQUIREMENTS.
5. PROVISION SHALL BE MADE FOR OFFSITE DRAINAGE AT THE FUTURE ROAD CENTRELINE.

URBAN HALF ROAD - 17.5m & 20.0m R/W

REVISED: 03/10

APPROVED:

APPROVED:

DWG. NO.

DATE: 05/94

DR-12

DRAWN: SEH





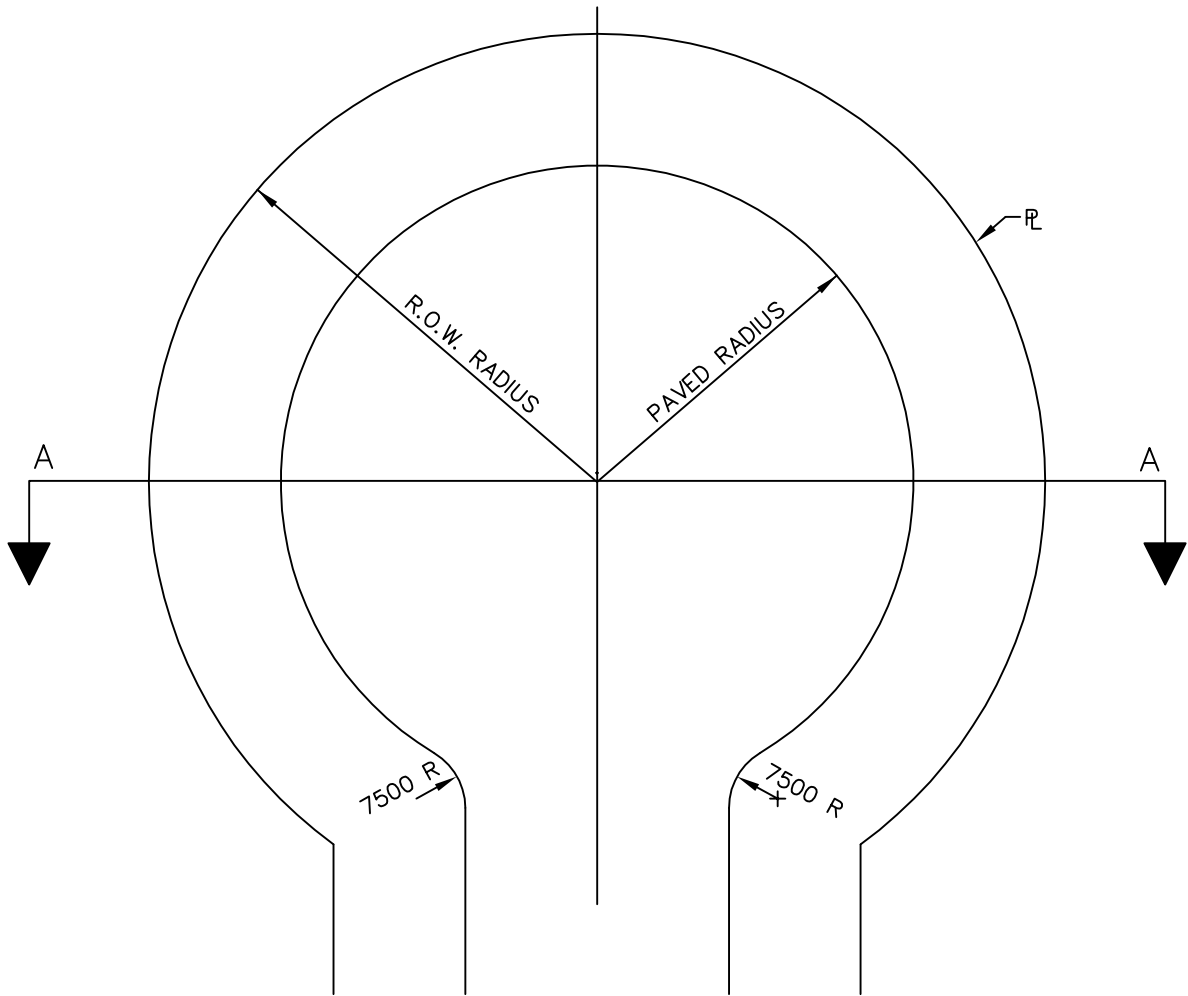

PLAN

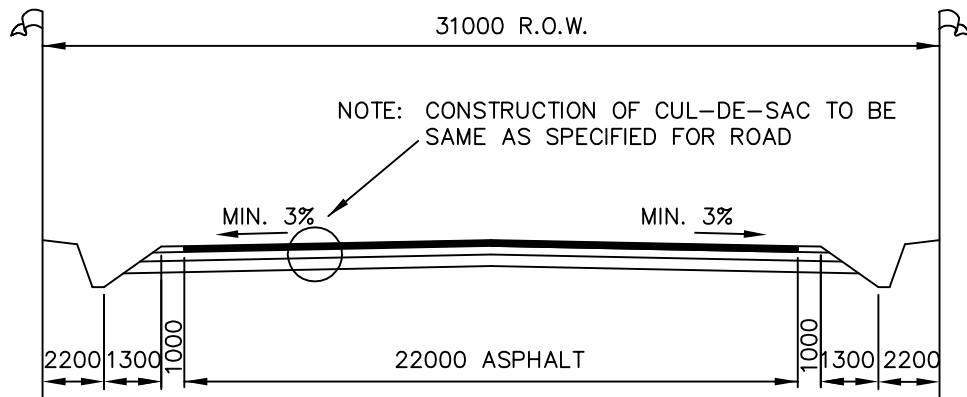

SECTION A-A

RURAL CUL-DE-SAC



**CITY OF CHILLIWACK**

REVISED:

APPROVED:

APPROVED:

DWG. NO.

DATE: MAR. 2002

DR-14

DRAWN: THJ

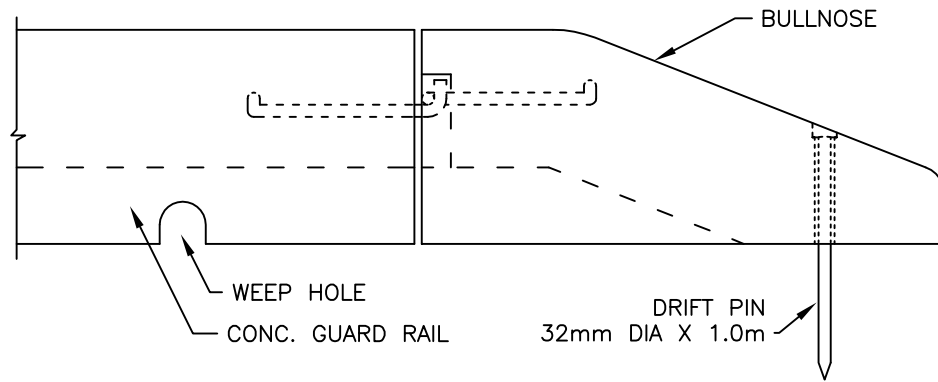
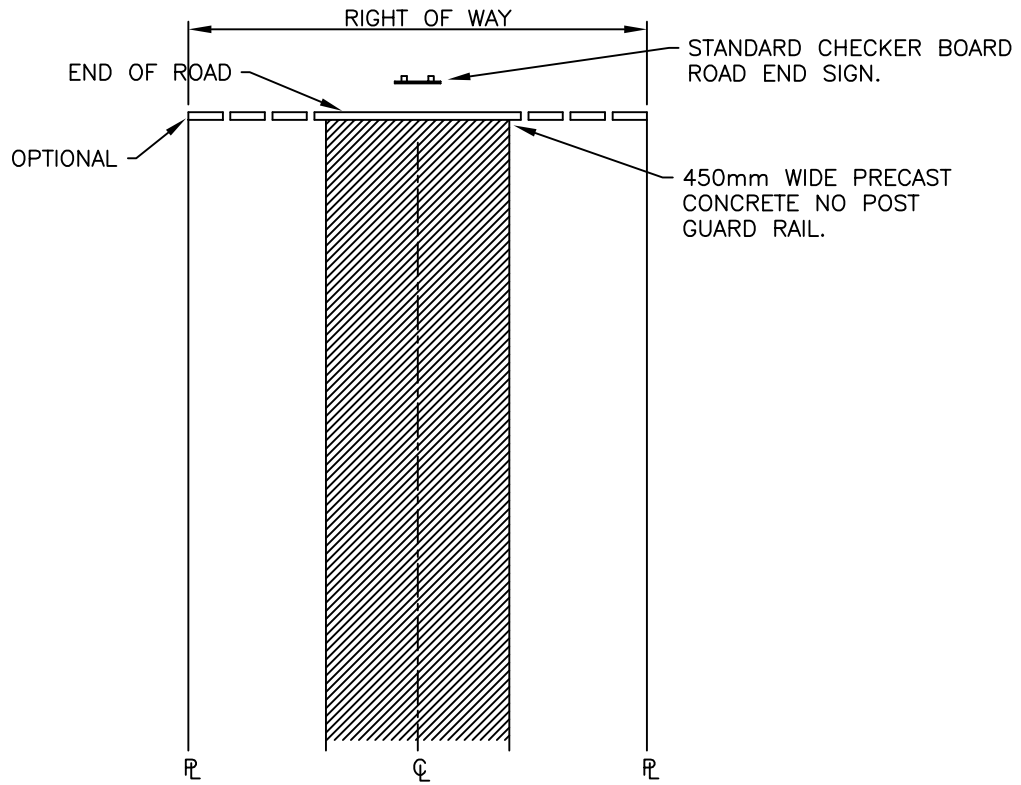

NOTES :

1. GUARD RAIL TO BE INTERLOCKING SECTIONS  
END SECTION TO BE A BULLNOSE WITH A 32mm DIA X 1.0m DRIFT PIN.
2. CONCRETE TO BE PAINTED WITH STANDARD YELLOW TRAFFIC MARKING PAINT.
3. GUARD RAIL TO EXTEND ACROSS FULL WIDTH OF ASPHALT.  
WHERE GROUND DROPS OFF 1.0m OR MORE AT THE END OF ASPHALT, EXTEND GUARD RAIL ACROSS THE FULL RIGHT OF WAY.
4. COMMENCE INSTALLATION WITH HOOK ON LEADING END.  
PLACE BULLNOSE SECTION FIRST. END OF CURB LINE IS A BULLNOSE SECTION WITH AN EYE CONNECTOR.

ROAD END BARRICADES



**CITY OF CHILLIWACK**

REVISED:

APPROVED:

APPROVED:

DWG. NO.

DATE: MAR. 2002

DR-15

DRAWN: THJ

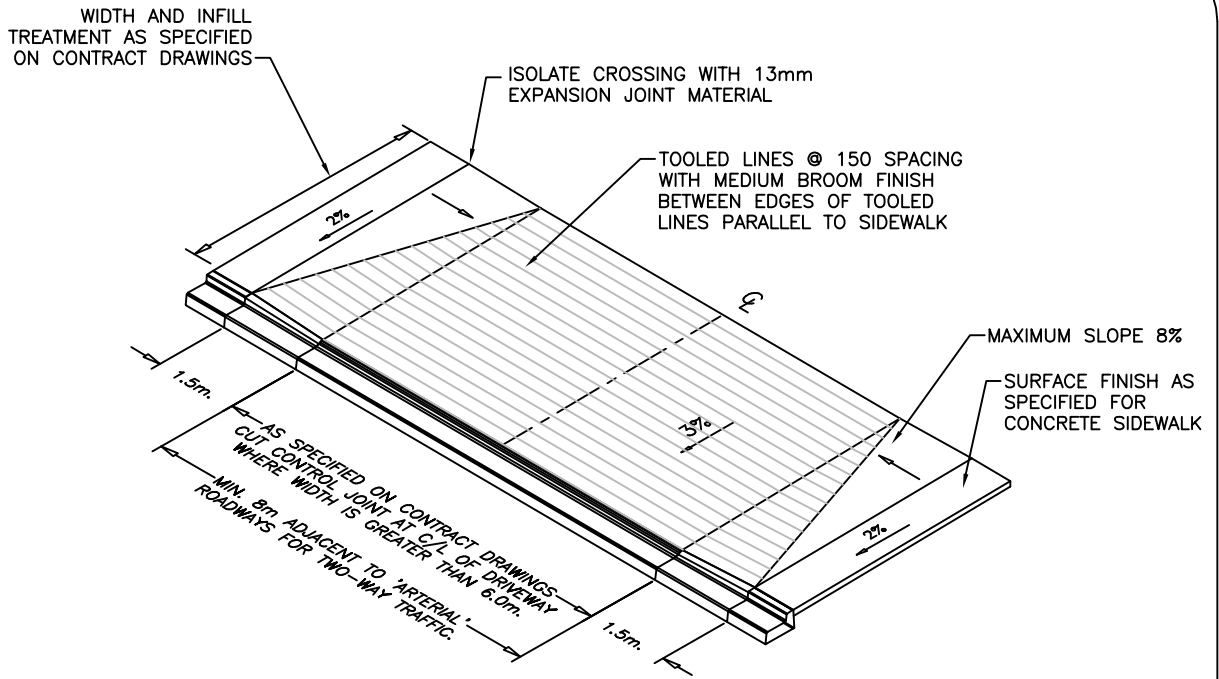

A. REDUCED CROSS-SLOPE

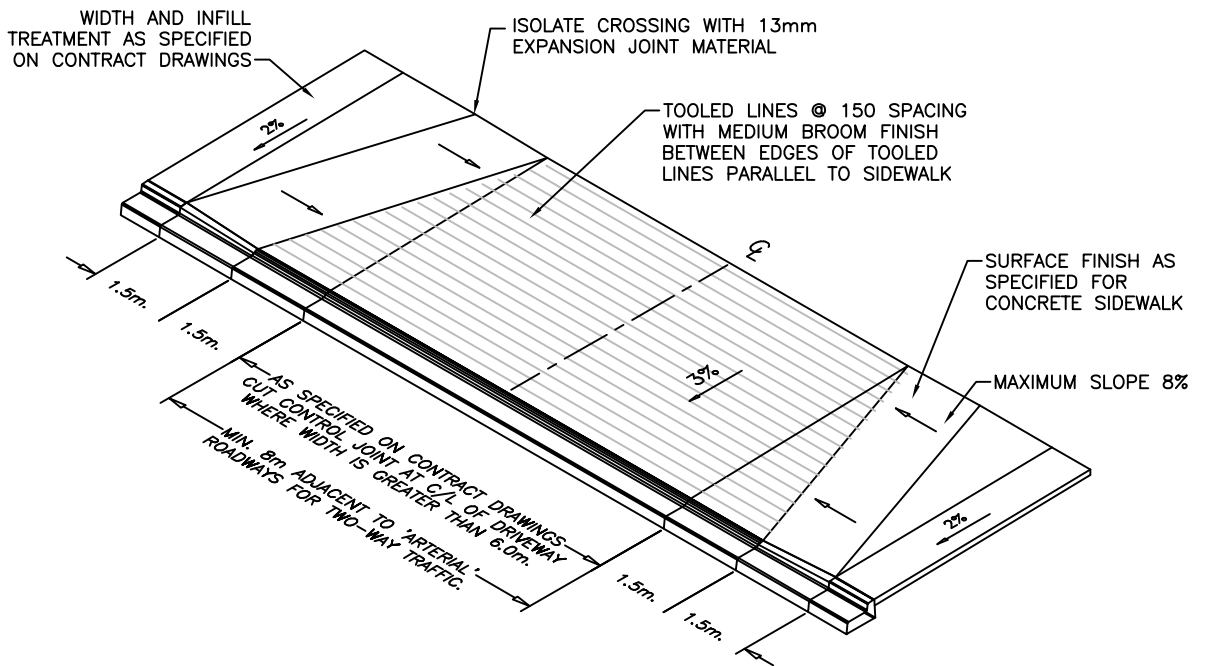

B. REDUCED CROSS-SLOPE/INCREASED RADIUS

- NOTE: 1. DRIVEWAYS ORIENTATED AT 90° TO CURB, UNLESS SPECIFIED OTHERWISE ON CONTRACT DRAWINGS.  
 2. REFER TO CONTRACT DRAWINGS AND MMCD SECTION 033020 FOR DETAILED SPECIFICATIONS.  
 3. FOR CROSS-SECTION DETAILS, SEE STANDARD DRAWING C-1.

DRIVEWAY CROSSING FOR BARRIER CURBS  
 REDUCED CROSS-SLOPE/INCREASED RADIUS

REVISED: 10/10

APPROVED:

APPROVED: JV

DWG. NO.

DATE: 06/04

DR-16

DRAWN: SEH



CITY OF  
**CHILLIWACK**



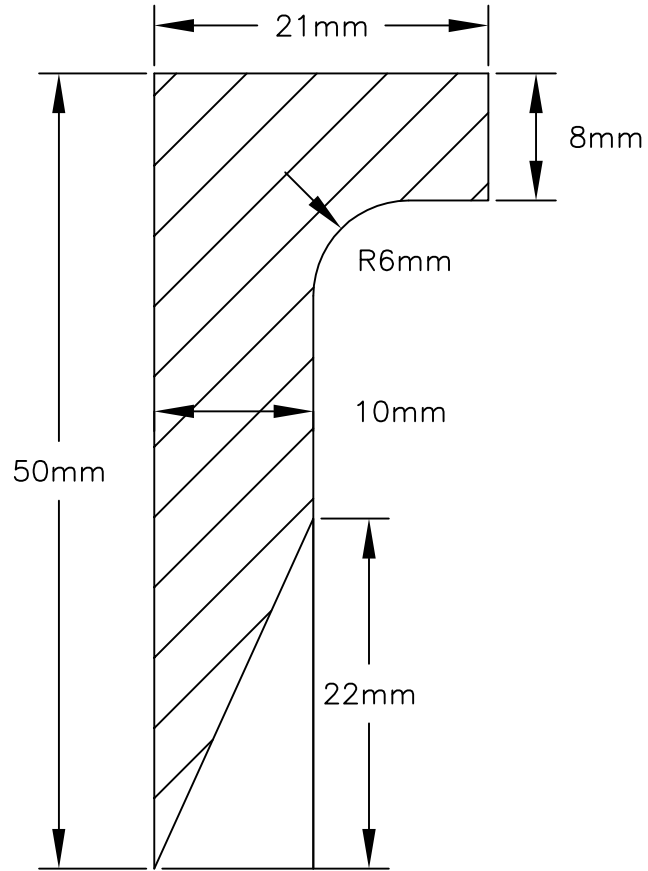

SIGN POLE WEDGE



**CITY OF CHILLIWACK**

REVISED:

APPROVED:

APPROVED:

DWG. NO.

DATE: 04/08

DR-17

DRAWN: SEH

